

ENG. NO.	ORDER NO.	PIN PLATING	HSG. MATERIAL
A-5219-09B	I5-31-1096	TIN	94V-2 NYLON
A-5219-09B-201	PRELIMINARY	TIN	94V-0 NYLON
A-5219-09BG	PRELIMINARY	GOLD	94V-2 NYLON
A-5219-09BG-201	PRELIMINARY	GOLD	94V-0 NYLON

HOUSING MATERIAL:

- 1 - NYLON TYPE 66, 94V-2, NATURAL
- 2 - NYLON TYPE 66, 94V-0, NATURAL

PIN MATERIAL: C27000 BRASS

PIN PLATING:

- 1 - POST PLATE .000120/(0.00305) MIN. TIN OVER .000040/(0.0010) MIN. NICKEL
- 2 - POST PLATE .000014/(0.00035) MIN. GOLD OVER .000080/(0.00200) MIN. NICKEL

NOTES:

- THESE HEADERS ARE FOR USE ON .062/(1.57) THICK P.C. BOARDS AND MATE WITH 3191-9 SERIES RECEPTACLES.
- CIRCUIT I.D. RIBS NOT PRESENT ON PARTS FROM TOOLS BUILT PRIOR TO 6/96.
- SEE PK-5219-001 FOR PACKAGING INFORMATION.

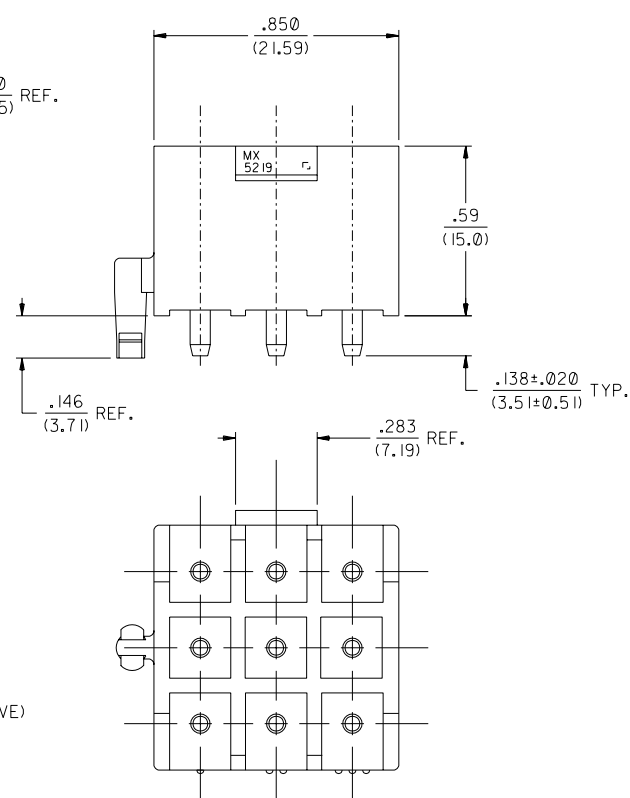
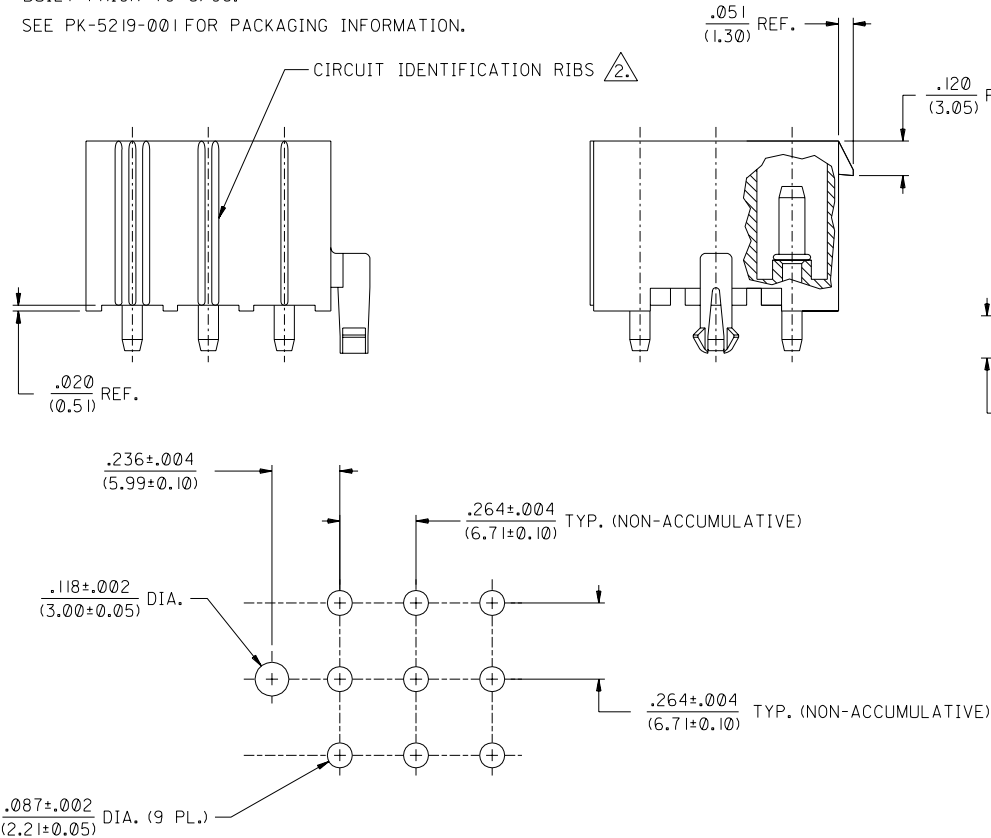
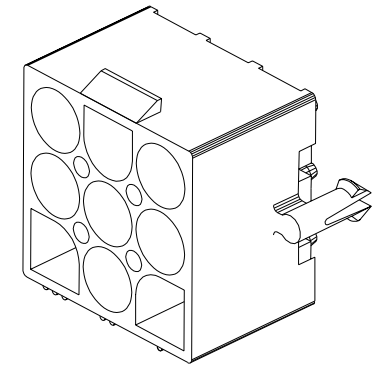
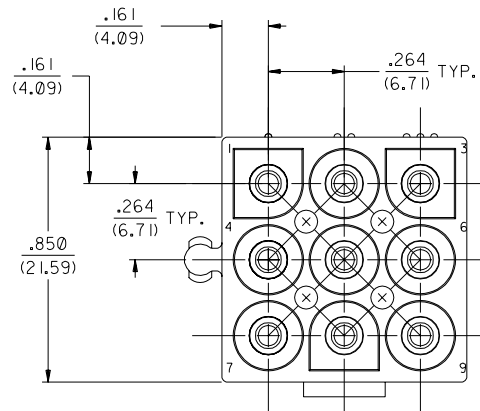

RECOMMENDED P.C. BOARD LAYOUT

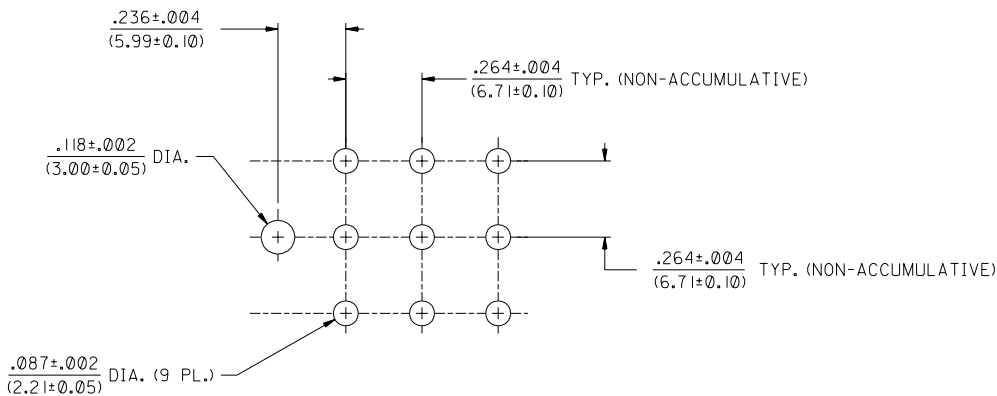

CI	ADD PACK'G (NOTE 3) UCP2003-2012 03/25/2003 ELHAG
C	REDRAWN ON CAD PER ECN #161470 05/23/96 CM

DIMENSIONS SHOWN (METRIC) INCH		▽ = 0		◻ = 0		REVISE ONLY ON CAD SYSTEM	
UNLESS OTHERWISE SPECIFIED TOLERANCES: ANGULAR ± 1/2°							
		INCH		METRIC			
3 PLACE	± .010	---					
2 PLACE	± .014	± 0.25					
1 PLACE	---	± 0.35					
DRAFT WHERE APPLICABLE MUST REMAIN WITHIN DIMENSIONS							
DRWG. BY	CM	CHK'D. BY	RW	FILE NAME	SDP199	SHEET NO.	DATE
APPR'D. BY	RAS	SCALE	3 : 1	MOLEX INC. AND SHOULD NOT BE USED WITHOUT WRITTEN PERMISSION	05/23/96	1 OF 1	05/23/96
SEE CHART				SDA-5219-09**			
MFG., SH., REV., LTR., REVISIONS				TITLE			
				.093/(2.36) SERIES 9 CIRCUIT HEADER ASSEMBLY			